

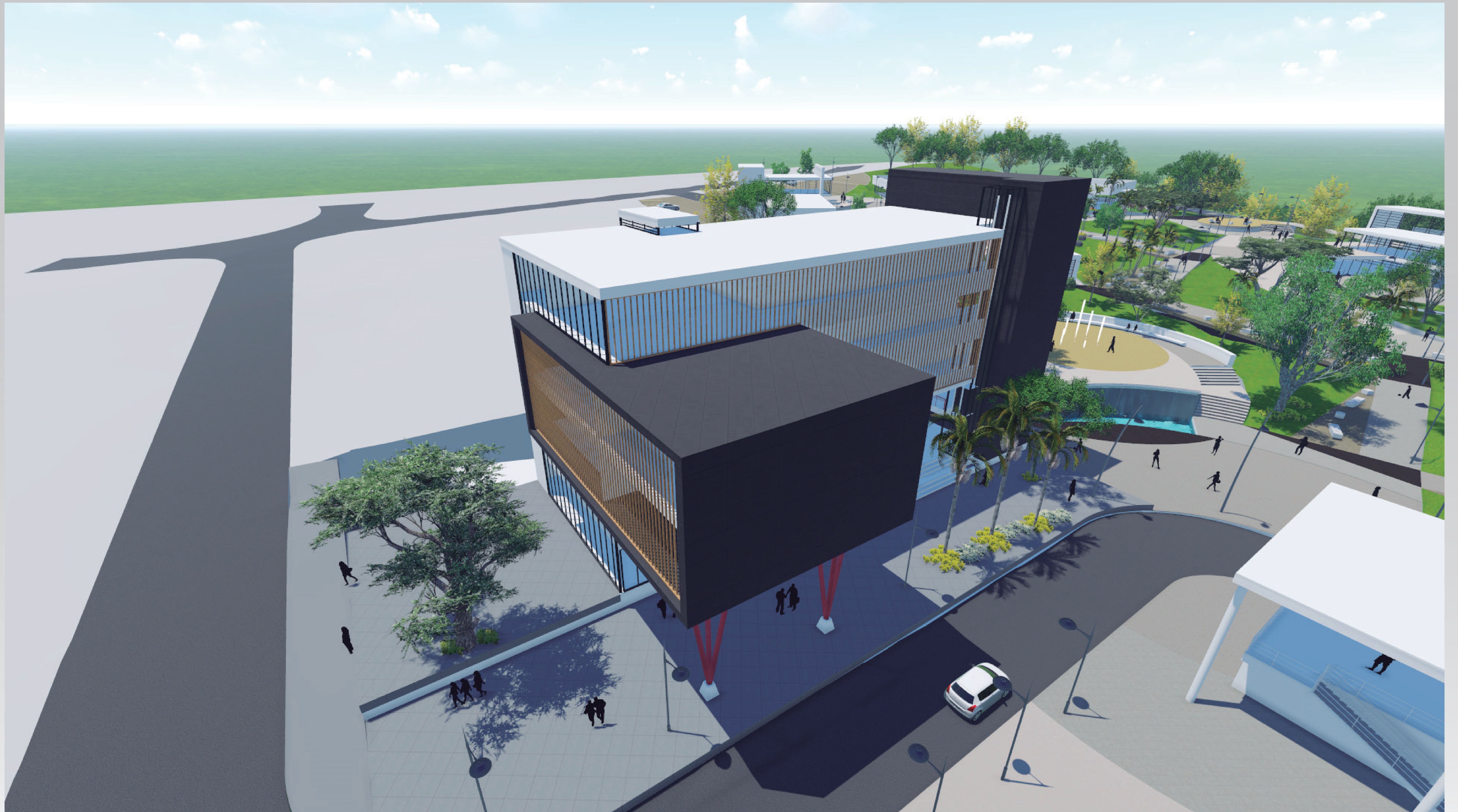

**Edificio Aulas y Oficinas  
Universidad de los Llanos  
Sede san Antonio**







# Localizacion



### CUADRO DE AREAS

	TOTAL	Resolución 0004 del 12 Mayo de 2008	Resolución 50001-1-11-0290 de 2011	Resolución 50001-2-14-0167 de 2011	Resolución 0744 de 2011	Resolución 50001-1-15-0653 de 2016	Presente Licencia
AREA LOTE	21451.6 m2						
AREA CONSTRUIDA							
SOTANO	1140,20 m2						1140,20 m2
PLANTA BAJA	110,82 m2					110,82 m2	
PISO 1	5618,75 m2	1112,54 m2	973,87 m2	855,48 m2	1260,10 m2	877,16 m2	539,60 m2
PISO 2	1739,03 m2	756,26 m2					573,07 m2
PISO 3	1885,59 m2	642,42 m2					573,07 m2
PISO 4	1296,48 m2						626,38 m2
PISO 5	539,60 m2						539,60m2
PISO 6	83,35 m2						83,35m2
AREA TOTAL CONSTRUIDA	12413,82 m2	2511,22 m2	973,87 m2	855,48 m2	1260,10 m2	2760,5 m2	4.052,65 m2
AREA LIBRE	16372,45 m2						
INDICE DE OCUPACION	0,26						
INDICE DE CONSTRUCCION	0,57						

### TABLA DE BAÑOS

PISOS	NUM OCUP	HOMBRES			MUJERES			EXIGIDO	PROPUESTO
		1/2	SANI	LAV	ORI	1/2	SANI		
PISO 1	258	129	3	3	4	129	4	4	
PISO 2	30	15	0	0	0	15	0	0	
PISO 3	175	87	2	2	3	87	3	3	
PISO 4	172	86	2	2	3	86	3	3	
PISO 5	127	63	1	1	2	63	2	2	
PISO 6	2	1	0	0	0	1	0	0	
TOTAL:		8	8	12		12	12		

	EXIGIDO	PROPUESTO
HOMBRES		
SANITARIOS	8	11
LAVAMANOS	8	12
ORINALES	12	13
MUJERES		
SANITARIOS	12	14
LAVAMANOS	12	14

### CUADROS ESTACIONAMIENTOS

TIPO	EXIGIDOS	PROPUESTOS
EDIFICIO AULAS Y PORTERIA	6	29
PRIVADO	6	29
PUBLICO	8	8
CARGA Y DESCARGUE	3	5
DISCAPACITADOS	1	3
BIBLIOTECA	9	9
PRIVADO	9	9
PUBLICO	7	7
CARGA Y DESCARGUE	2	2
DISCAPACITADOS	1	1
POLIDEPORTIVO	10	10
PRIVADO	10	10
PUBLICO	4	4
VISITANTES	0	1

TIPO	EXIGIDOS	PROPUESTOS
ESTACIONAMIENTOS EDIF AULAS Y AUDITORIO	23	23
PRIVADO	23	23
PUBLICO	17	17
CARGA Y DESCARGUE	4	4
DISCAPACITADOS	2	2

TIPO	EXIGIDOS	PROPUESTOS
ESTACIONAMIENTOS EDIF AULAS Y OFICINAS	34	11
PRIVADO	34	11
PUBLICO	25	25
CARGA Y DESCARGUE	7	5
DISCAPACITADOS	2	0

TIPO	EXIGIDOS	PROPUESTOS
CUADRO GENERAL DE ESTACIONAMIENTOS SEDE SAN ANTONIO		
PRIVADO	82	82
PUBLICO	61	61
VISITANTE	0	1
CARGUE Y DESCARGUE	16	16
DISCAPACITADOS	6	7
MOTOS	110	188
BICICLETAS	0	120



# Planta de Implantación



Edificio Aulas  
y Oficinas



# Planta de Sotano

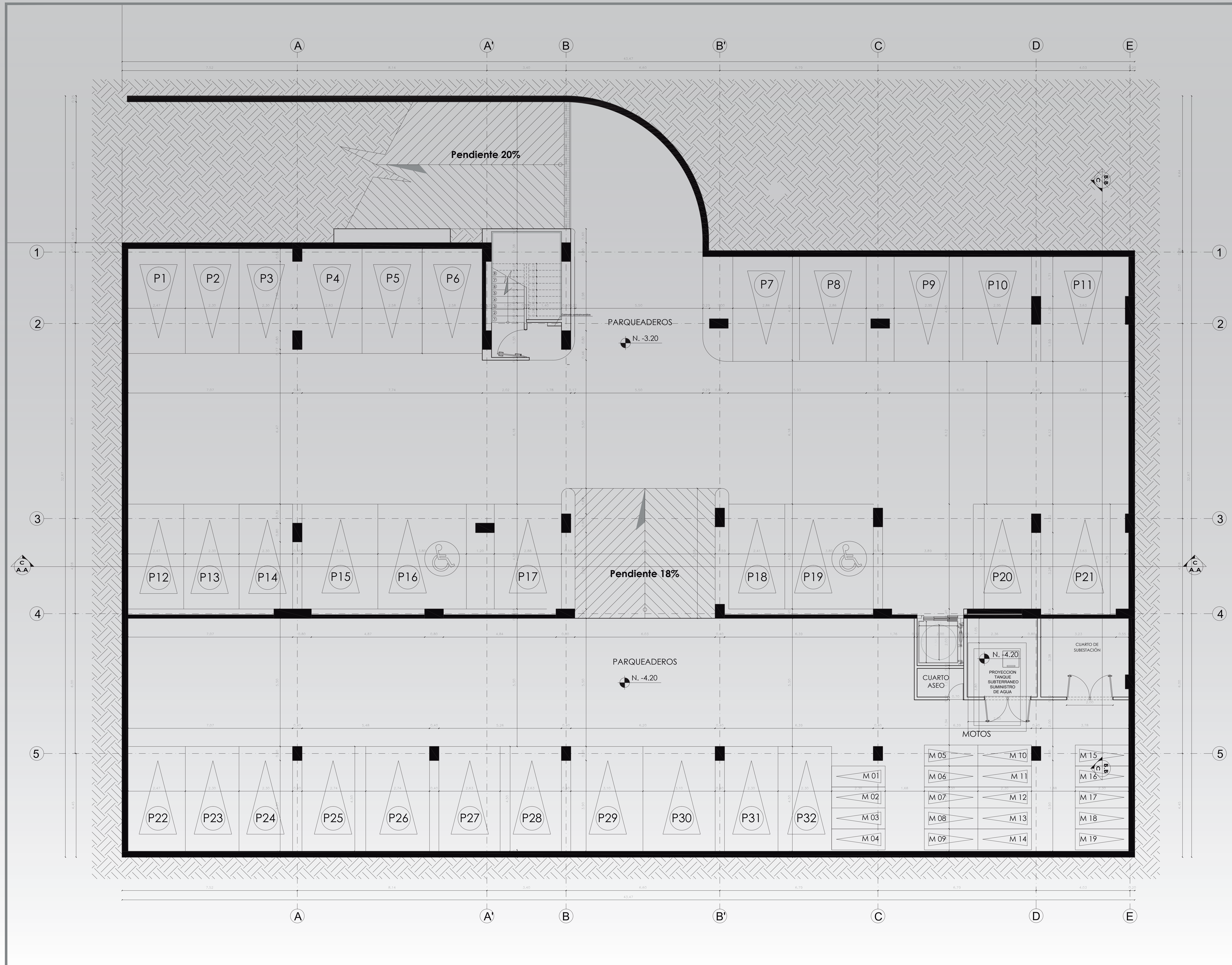



# Planta Primer Piso

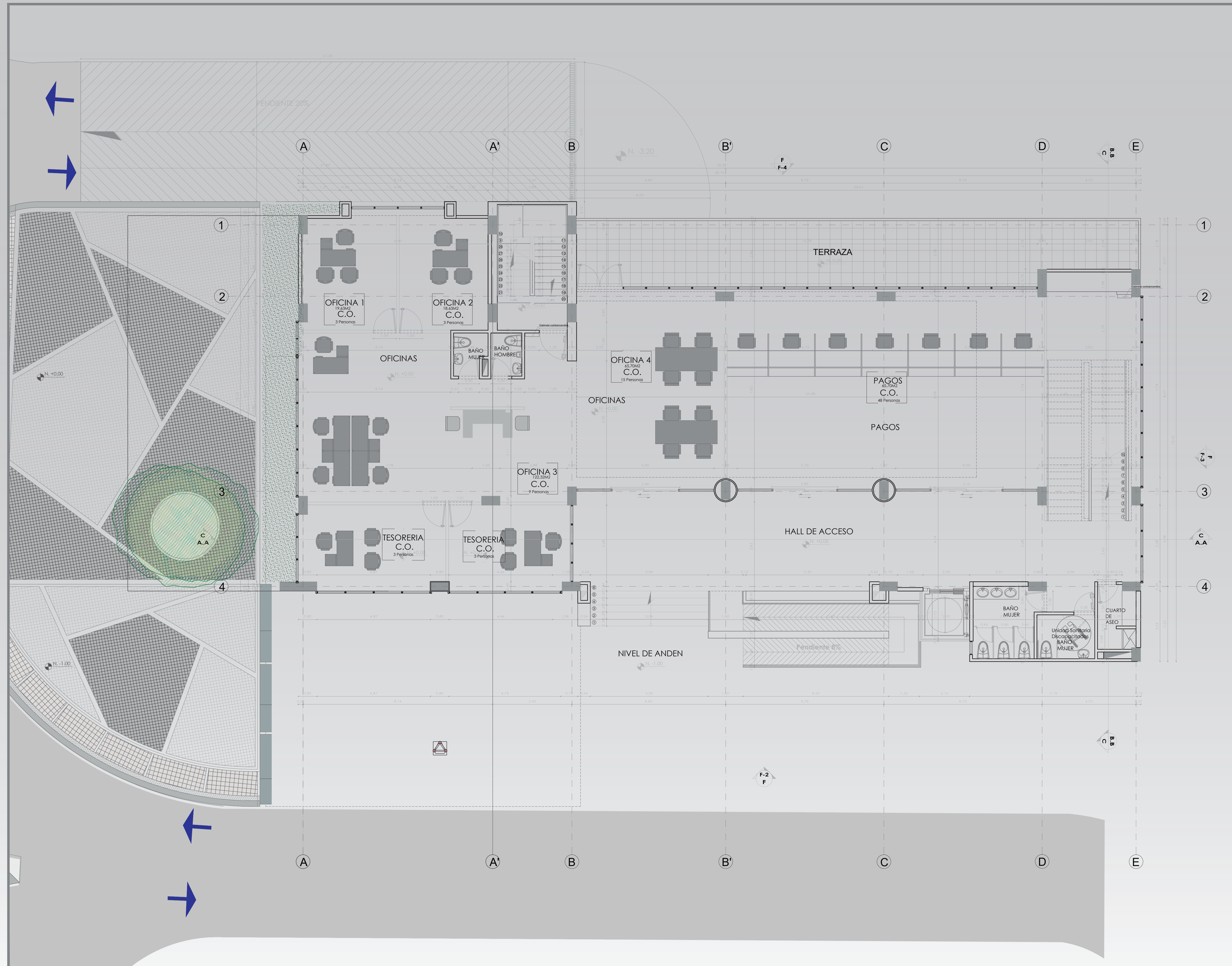



# Planta Segundo Piso

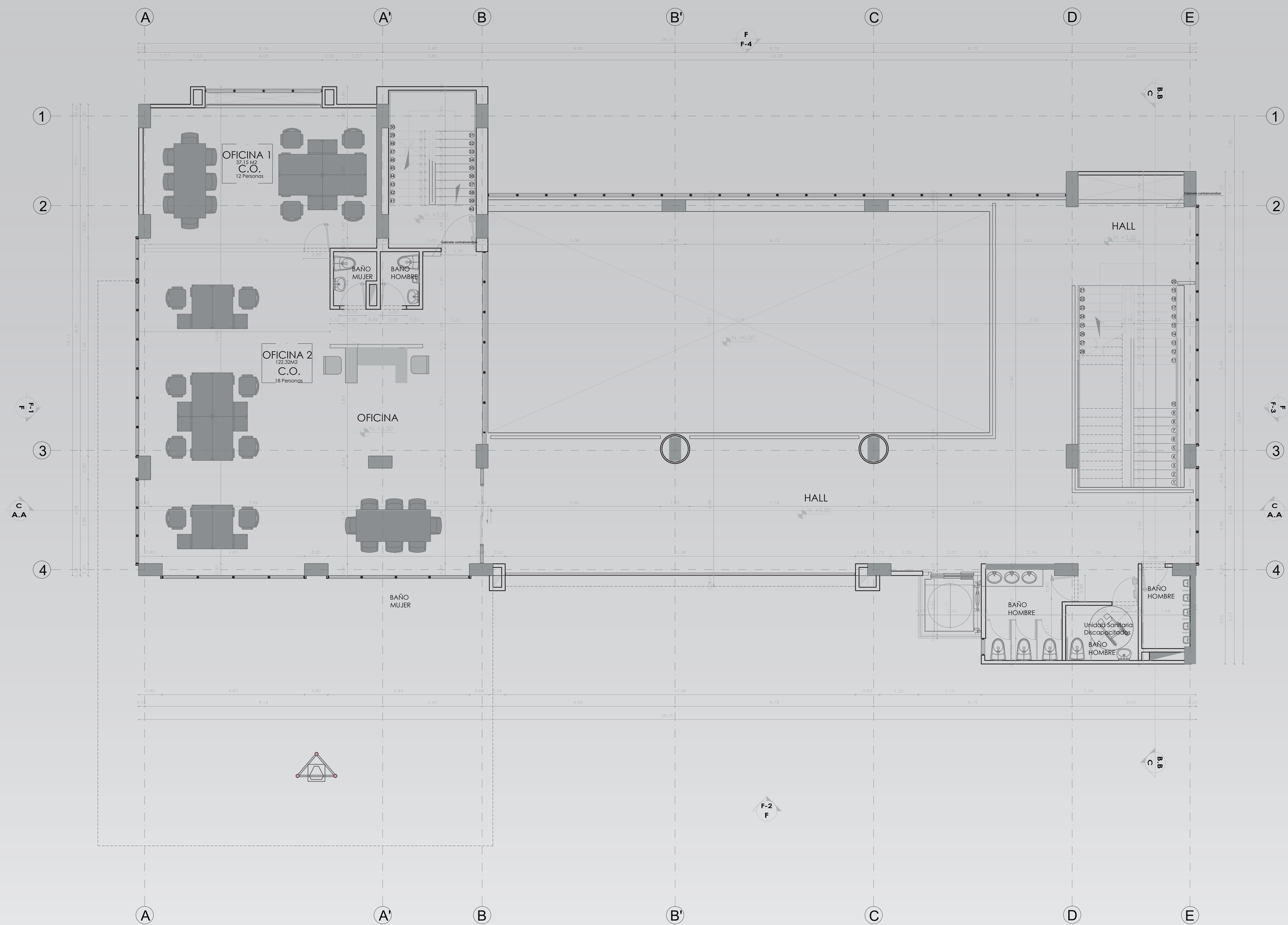



# Planta Tercer Piso

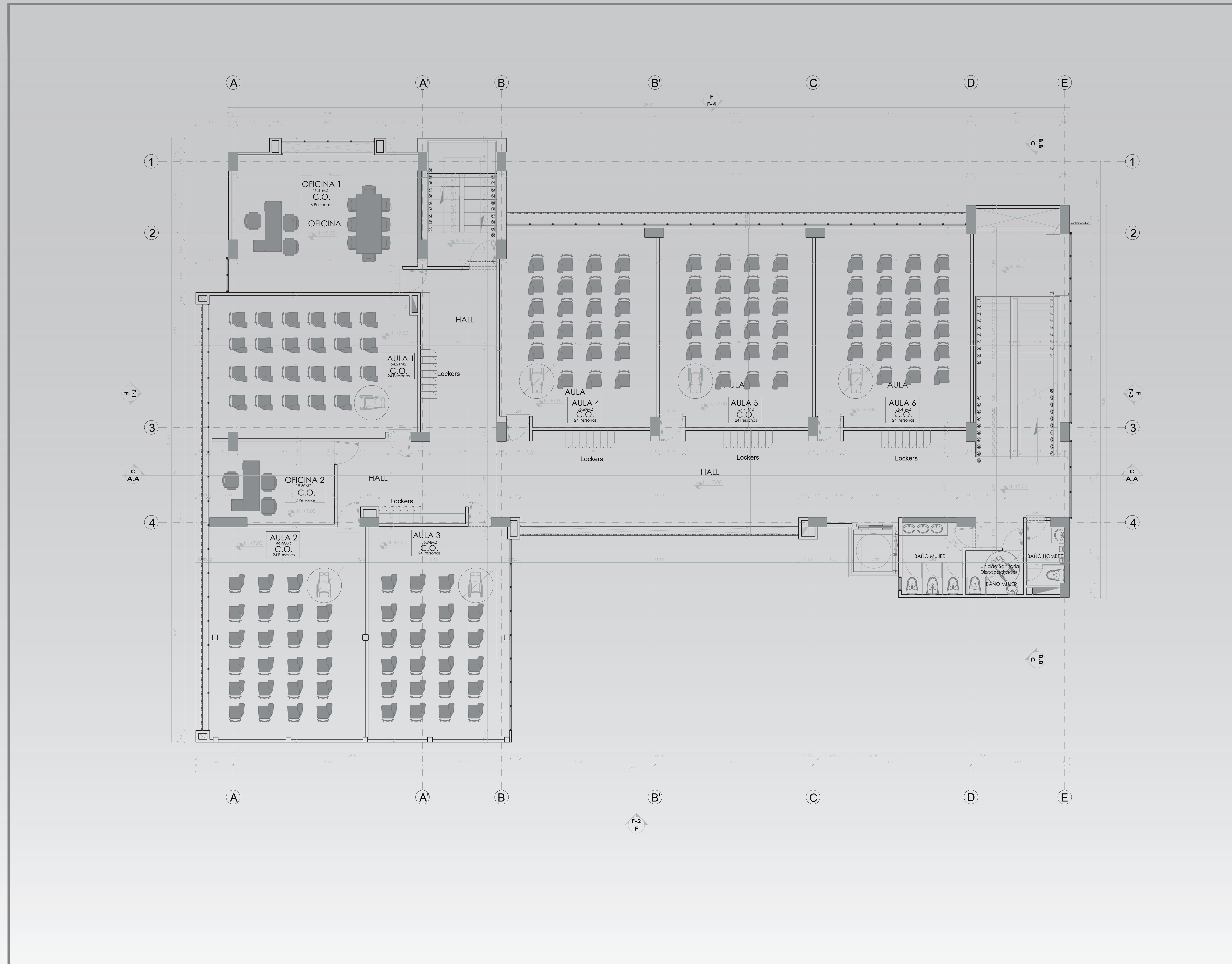



# Planta Cuarto Piso

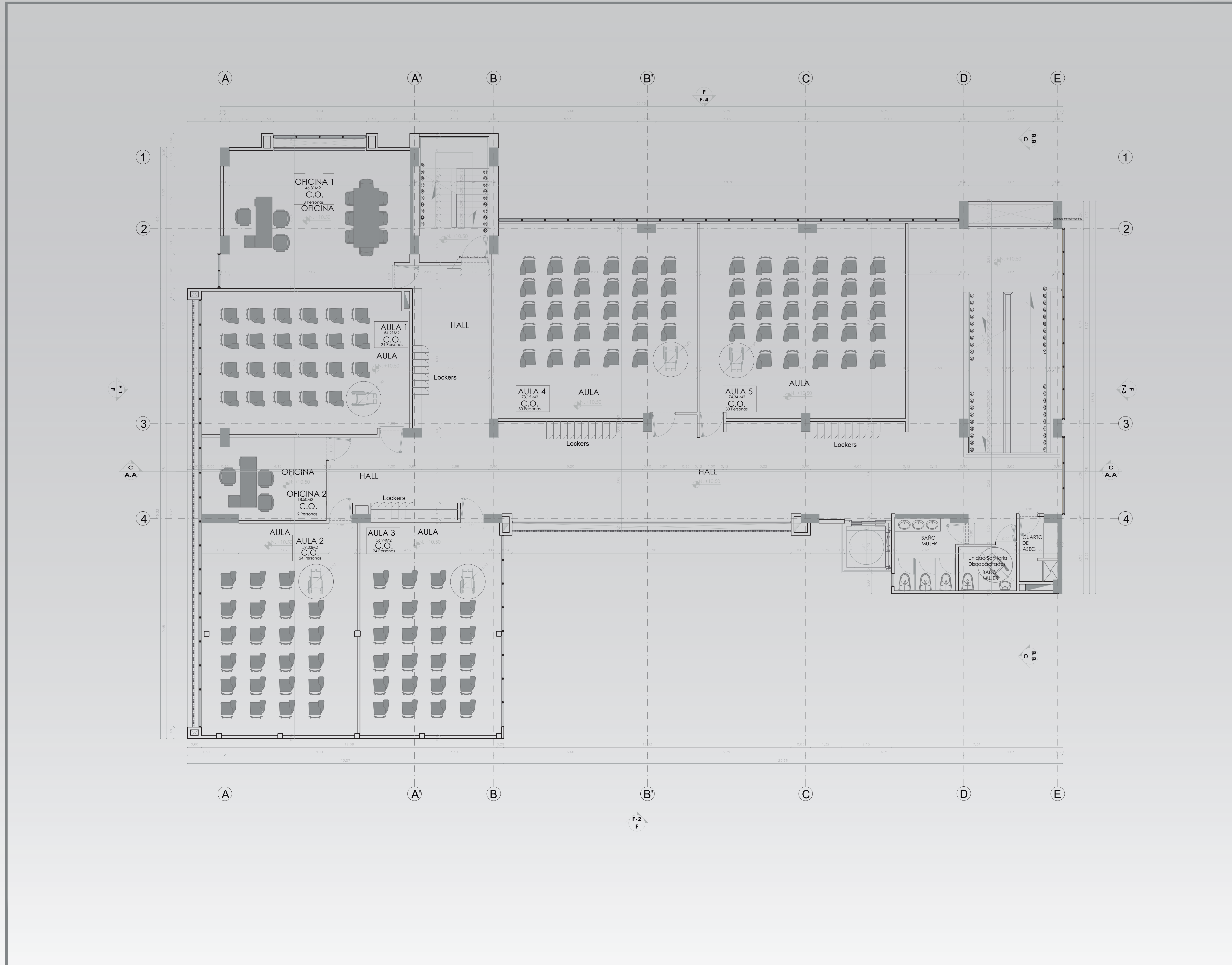



# Planta Quinto Piso

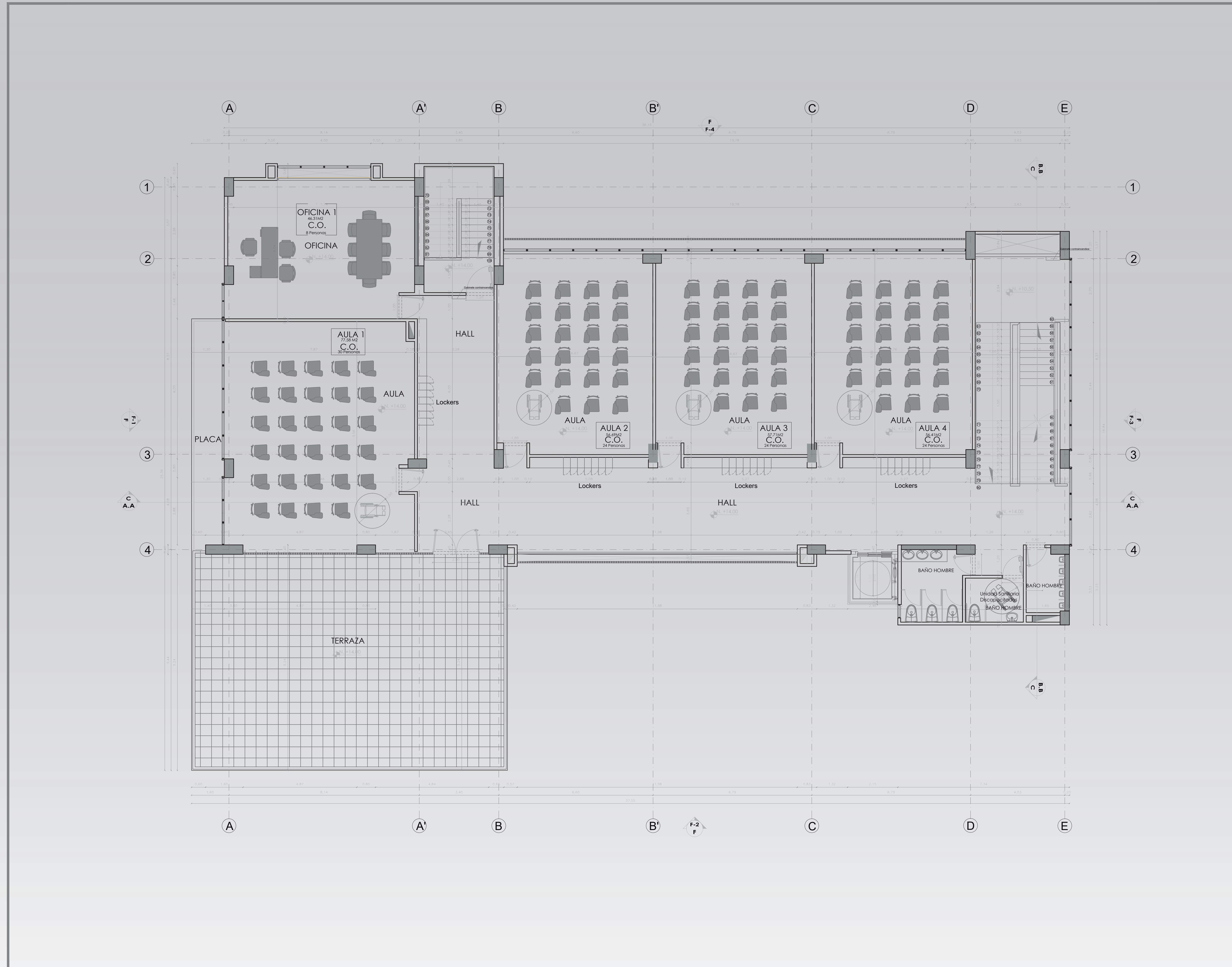



# Planta Sexto Piso

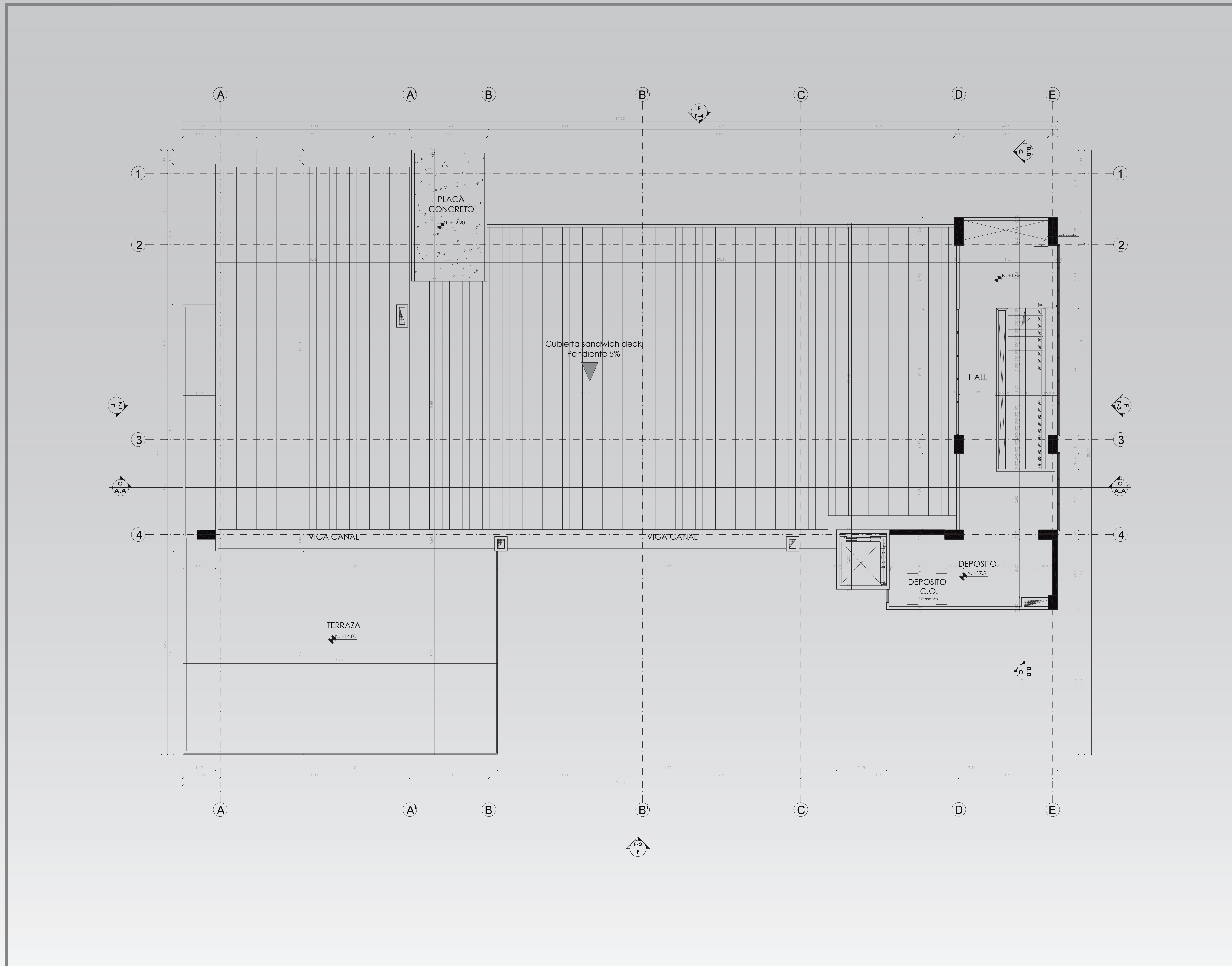



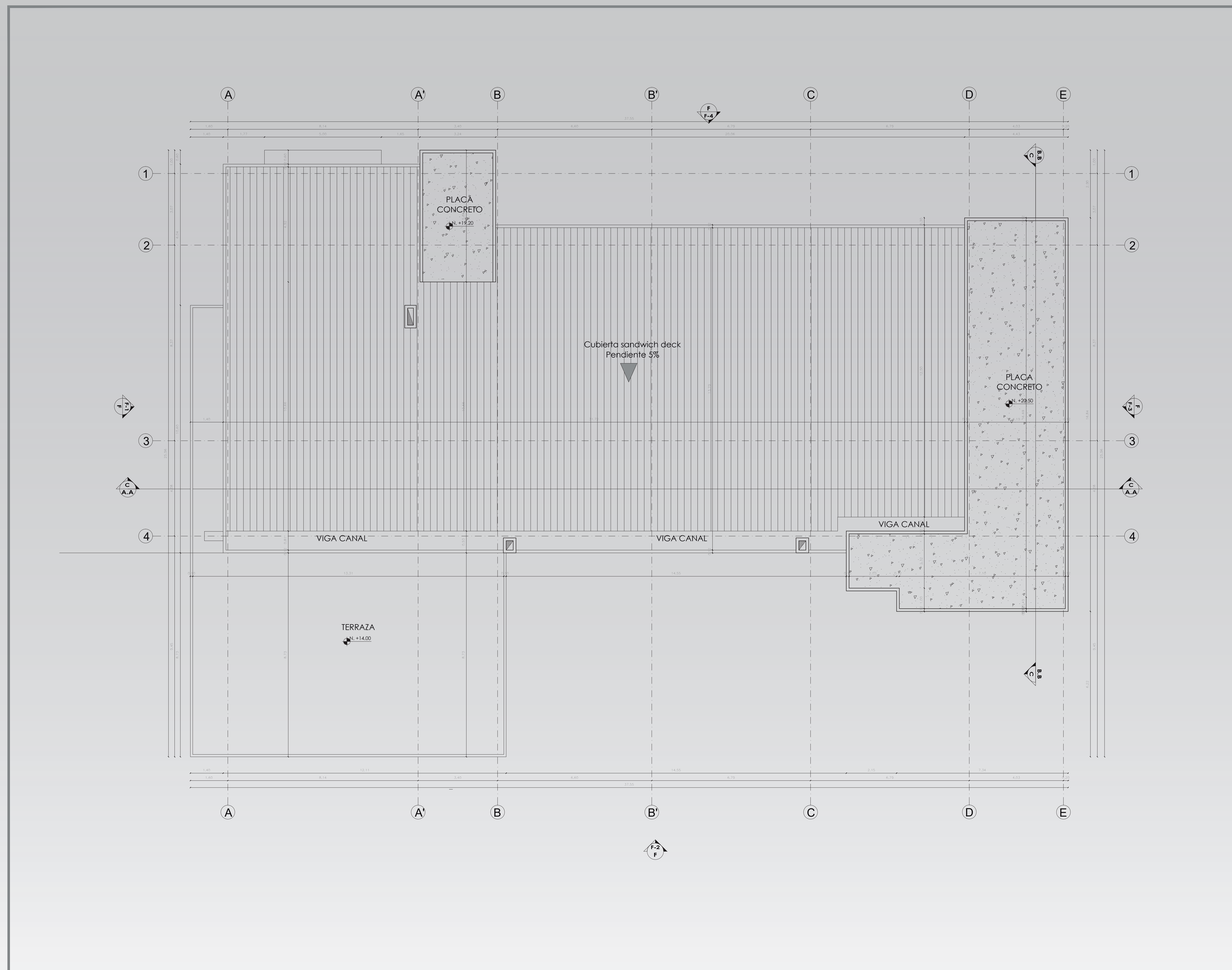

# Planta de Cubierta



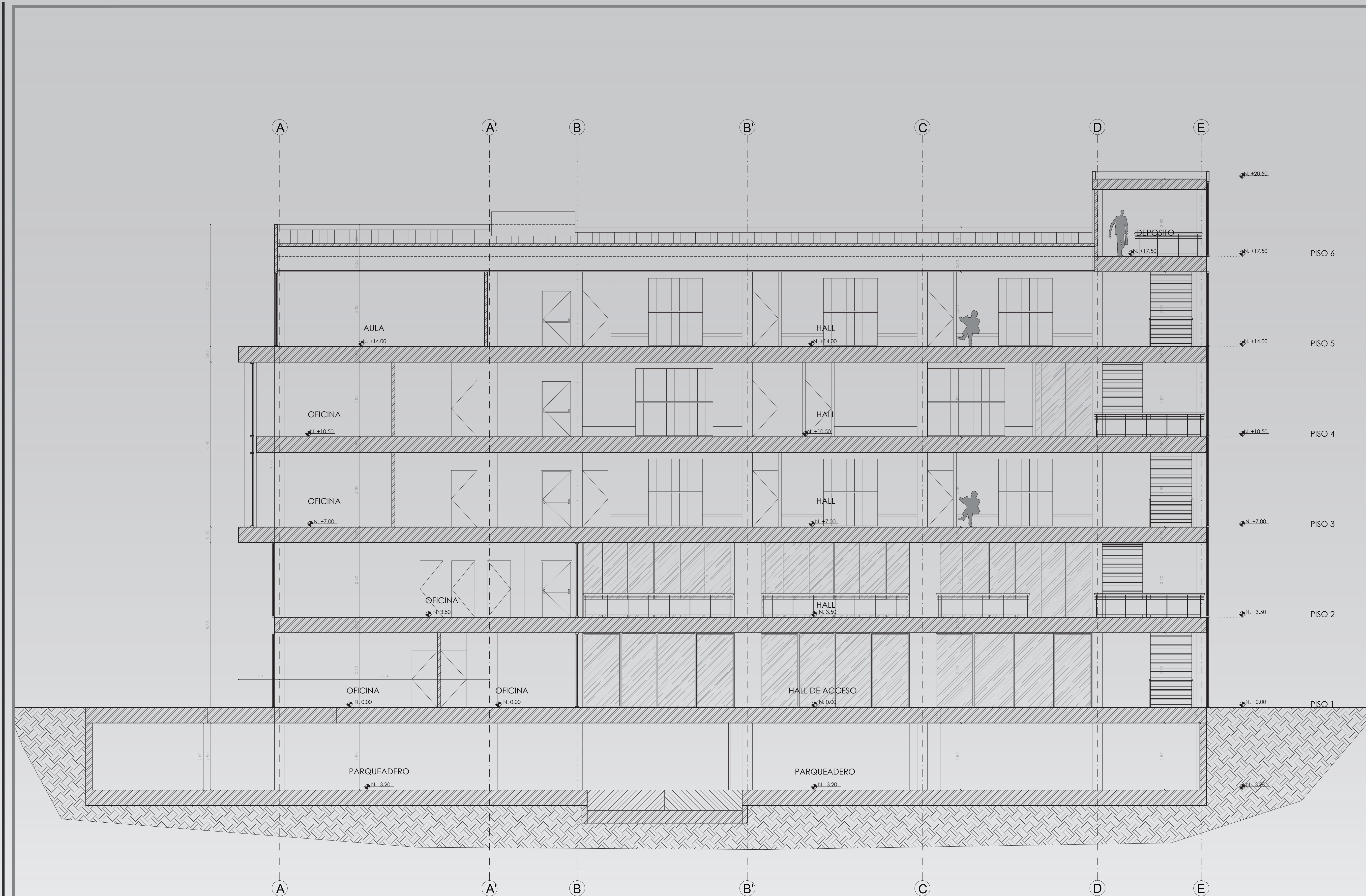

# Corte A-A



 CORTE A-A  
ESC 1:75



# Corte B-B

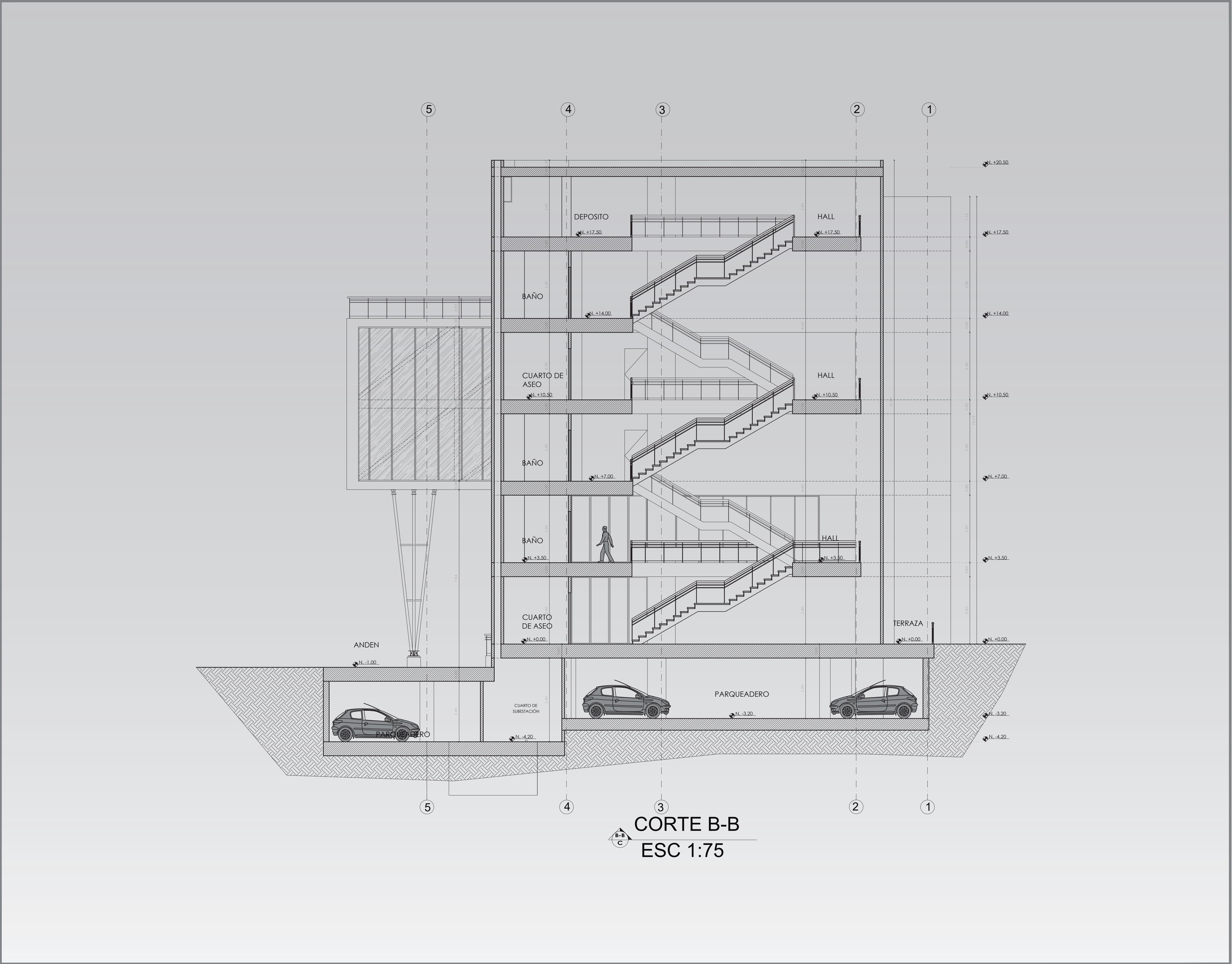



# Fachada Principal

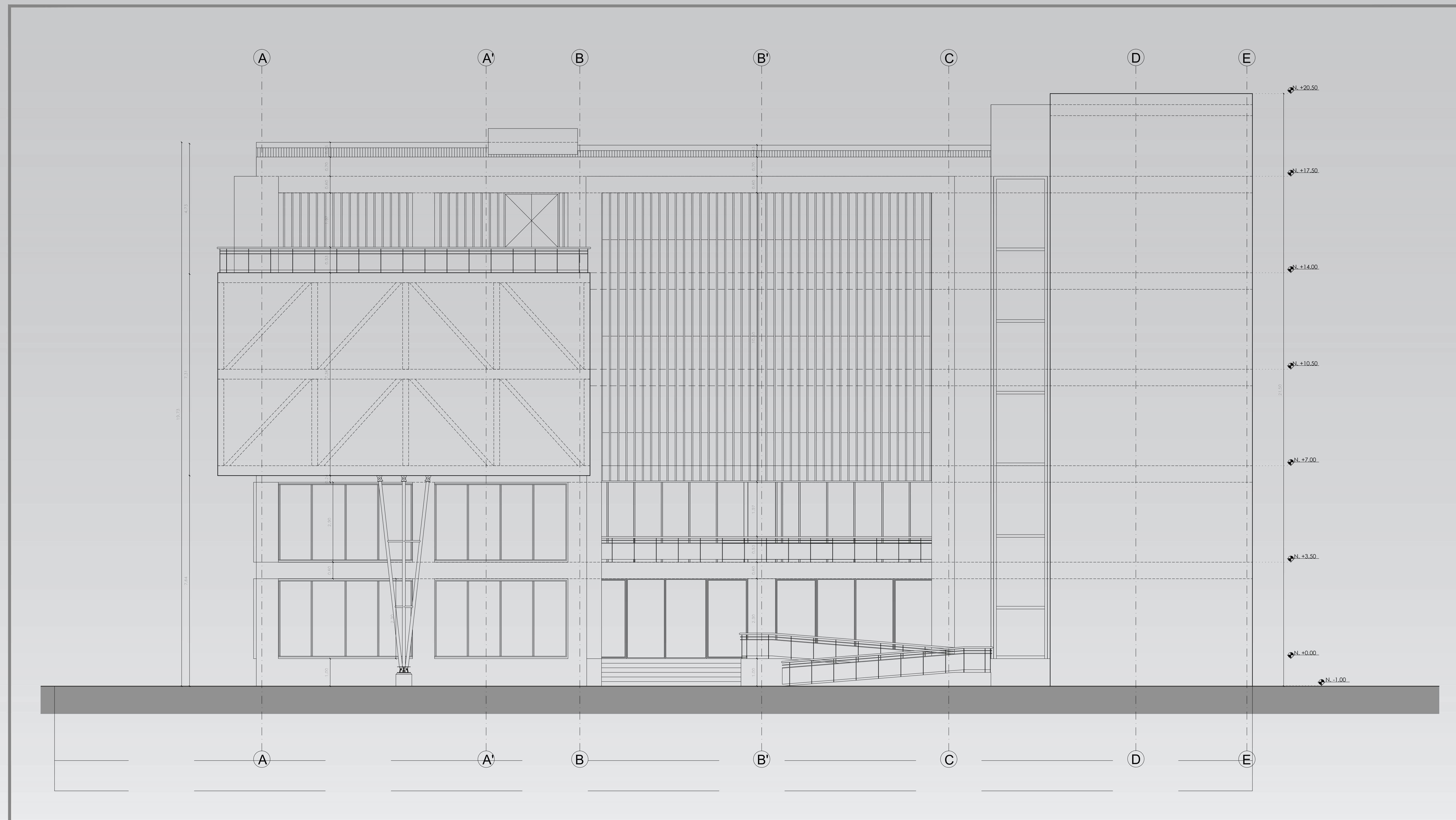



# Fachada Posterior

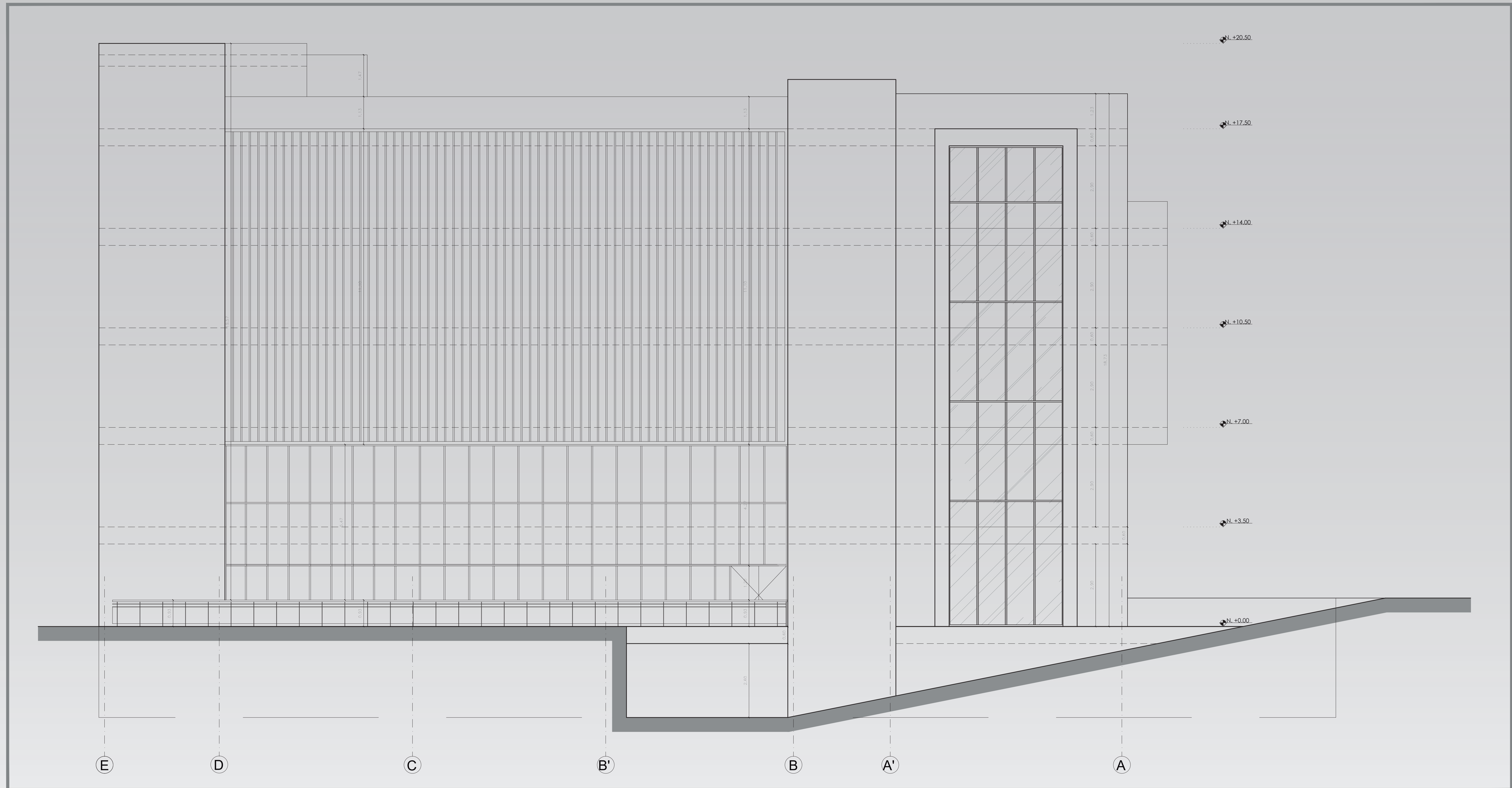



# Fachada Lateral derecha

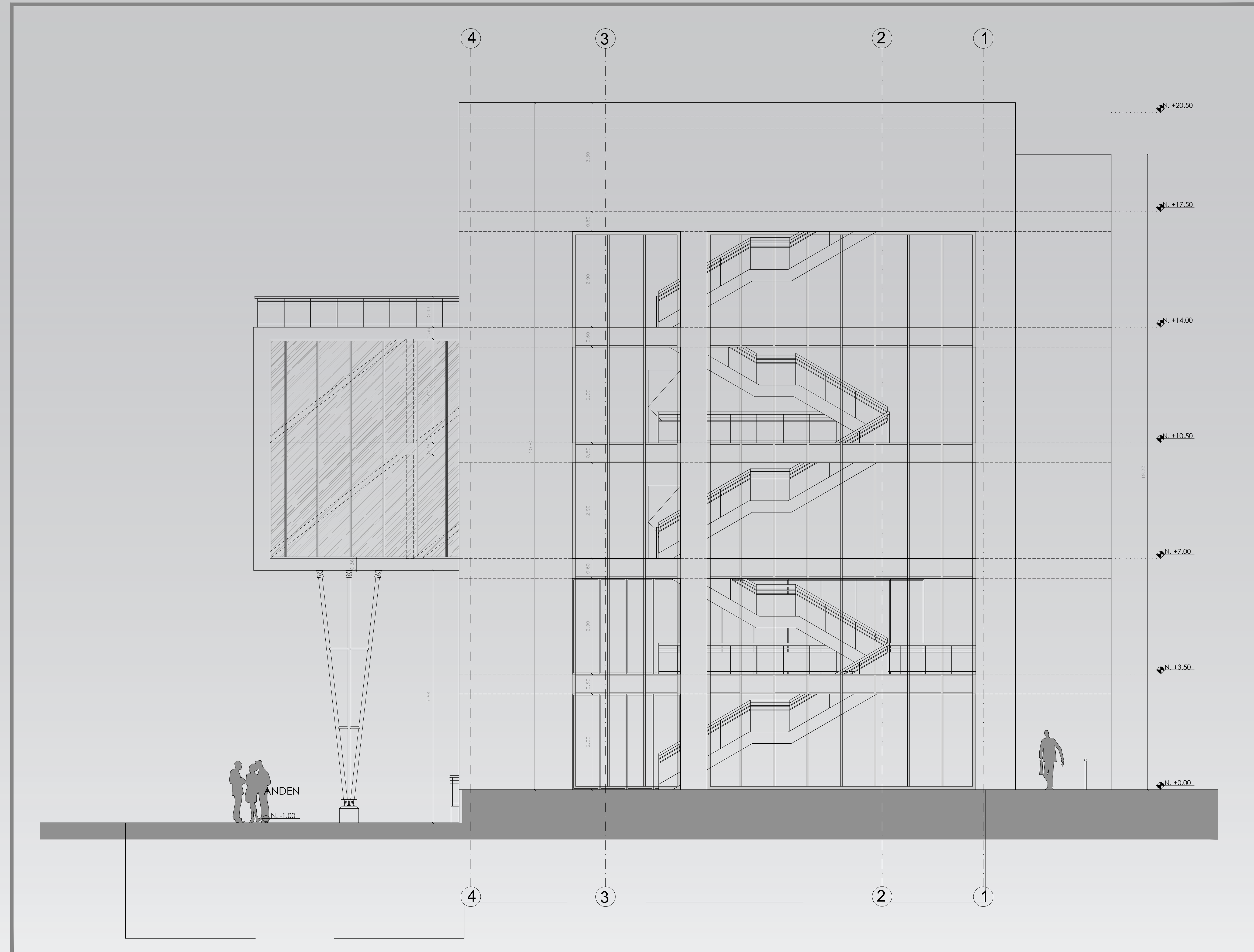







# Renders del Proyecto













